



KL 1500 LCD

- Easy and reproducible operation.
- Functional lamp compartment for quick lamp replacement.
- Filter drawer for selection of color filters.
- Swing-in input optics for homogenization of light input.
- Easy stacking capability with access to all features and functions.

- The design of a low-noise fan in combination with optimum air venting at the back of the unit helps contribute to quiet and pleasant working conditions.

- **Approvals:**
The KL 1500 LCD has been approved and certified by VDE and UL (120-Volt version for U.S. and Canada) and carries the CE conformity label (230-Volt version).

- Manufactured in the EU.

KL 1500 LCD

A benchmark in the field of 150-Watt AC light sources

Compact and cost-effective, with outstanding design and excellent function and performance parameters – these are the main features of the KL 1500 LCD.

Display for color temperature and operating modes, electronic and mechanical light control, as well as new maximum light level are just a few of the special advantages of this light source.

Constant light flux output is maintained independent of fluctuations in the supply voltage network ($\pm 10\%$).

The time tested features of SCHOTT light sources have been implemented again in the KL 1500 LCD.

KL 1500 LCD			
Type designation		General data	
Dimensions (W x D x H)		(mm)/(inch)	Ca. 200 x 265 x 170/ca. 7.9" x 10.4" x 6.7"
Weight		(kg)	Approx. 4.8
Cooling		Low-noise fan	
		Part-No.	Electrical data
Operating voltage	120 volt version	150 201	100 V ~ 50/60 Hz, 120 V ~ 60 Hz
	230 volt version	150 200	220 V ... 240 V ~ 50/60 Hz
Protection		Class II	
Lamp type		Halogen reflector lamp Type EFR	
Lamp voltage rating (V)		15	
Lamp power rating (W)		150	
Average lamp service life	level 4	(h)	1500
	level 5	(h)	150
		Illumination data	
Illumination flux		(lm)	600
Light control		Electrical and mechanical	
Active light guide diam.		(mm)/(inch)	Max. 9/Max 0.35"
		Certification marks	
120 volt version		CSA (C/US)	
230 volt version		VDE/EMV	

KL 1500 LCD

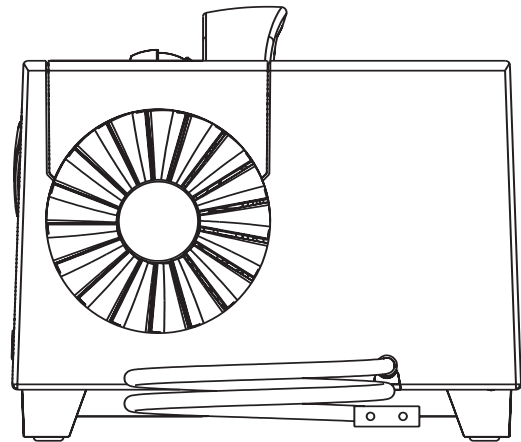
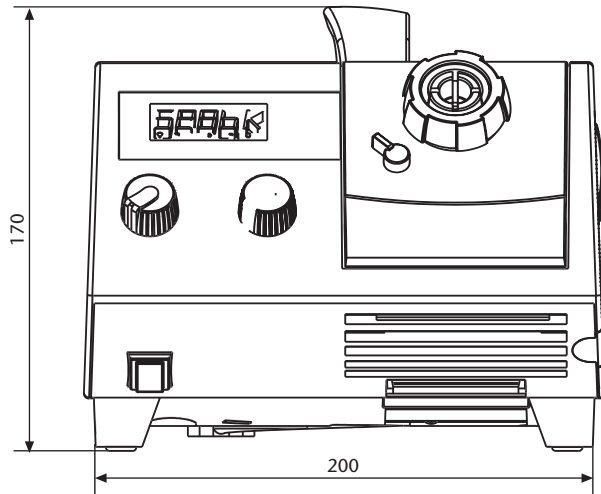
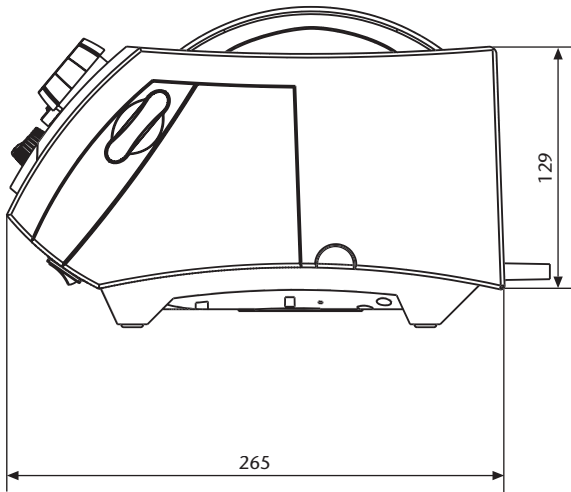

Fiber Optics

SCHOTT North America, Inc.

62 Columbus Street

Auburn, NY 13021-3137

USA

Phone: +1315/255-2791

Fax: +1315/255-2695

E-mail: fiberoptics.auburn@us.schott.com

www.us.schott.com/fiberoptics

SCHOTT