



DCR® IV Light Source with DDL lamp, A20890

DCR® IV Light Source Models	
Part No.	Description
Standard Light Sources US Power Cord Included	
A20890	Integrated Equalizer™ (complete with Reference Modulamp® assembly and DDL Lamp).
A20891	Integrated Equalizer™ (complete with Modulamp® assembly and DDL Lamp. Does not include reference bundle).
Light Source with Iris Diaphragm US Power Cord Included	
A20892	Modulamp® with DDL Lamp
Light Source without Modulamp® Unit US Power Cord Included	
A20893	No Lamp – Power Supply Only
Standard Light Sources EU Version - No Power Cord Included	
A20895	Integrated Equalizer™ (complete with Reference Modulamp® assembly and DDL Lamp).
A20896	Integrated Equalizer™ (complete with Modulamp® assembly and DDL Lamp. Does not include reference bundle).
Light Source with Iris Diaphragm EU Version - No Power Cord Included	
A20897	Modulamp® with DDL Lamp
Light Source without Modulamp® Unit EU Version - No Power Cord Included	
A20898	No Lamp – Power Supply Only
Expansion Cable	
A20665	Triple Cable with Plug, 12"

DDL lamp and Modulamp® units can be purchased separately.

Options

- Rear baffle.
- Dimmer lock.
- Mechanical shutter.
- Infinite setting, thirteen blade iris diaphragm unit available to reduce intensity while maintaining color temperature. Cannot be used with reference Modulamp®.
- Expansion cable.

DCR® IV Light Source

DC regulated light source with integrated Equalizer™ light feedback to provide stabilized light output for the most demanding machine vision inspection applications. (See DCR® III Plus datasheet for base description.)

Benefits

- Stable lamp output over the life of the lamp and minimized lamp to lamp variation.
- Remote controllable using integrated RS232 interface.

Standard Features

- **Flexible** - Two configurations available:
 - A. DCR® IV used with a reference Modulamp® unit and off-the-shelf fiber optics, maintains DDL lamp output at $\pm 2\%$ over the life of the lamp and $\pm 8\%$ lamp to lamp.
 - B. For even greater control, use the DCR® IV with fiber optic products that have an integrated reference bundle; special order only. This will maintain DDL lamp output and lamp to lamp variation within $\pm 1\%$.
- All of the features of the DCR® III Plus Light Source including control of up to three additional DCR® III light sources via an expansion cable.
- LED's located on the front panel indicate that the lamp intensity is stabilized.
- Easy to use front panel controls for calibration and intensity control.
- CSA certified to UL, CE compliant to low voltage and EMC directives.
- Universal input voltage – accepts 90 to 265 VAC, 50/60 Hz.
- Stackable, with retractable handle and detachable cord.
- 2-year warranty (excludes lamp and socket).
- Manufactured in the USA.

Performance Specifications

Light Output with Reference Modulamp Unit	$\pm 2\%$
Light Output with Independent Reference Bundle	$\pm 1\%$
Lamp to Lamp Variation with Reference Modulamp Unit	$\pm 8\%$
Lamp to Lamp Variation with Independent Reference Bundle	$\pm 1\%$

Power Supply Specifications

Rated Power Output	150 Watts
Output Voltage	0.0, 0.5 to 20.5 VDC
Input Voltage Rating, 50/60 Hz.	90 to 265 VAC
Power Factor Correction @ 230 VAC, 50 Hz.	$> 0.99, < 4^\circ$
Hold-up Time, Nominal AC Input, Full Load	8.3 milliseconds
Line Regulation, Over Entire Input Range	$\pm 0.5\%$
Lamp Type	DDL, Ushio or GE, 150 W Halogen Bulb
Current Limit Set Point	8.5 Amps
Temperature Range: Operating	0° to 45°C
Storage	-25° to 85°C
Relative Humidity, Non-condensing	5% to 95%

DCR® IV Light Source

Dimensions in () are in mm

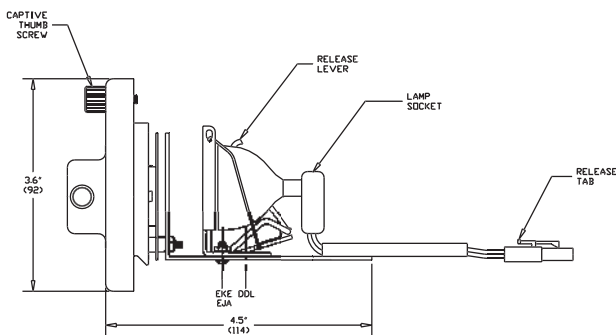
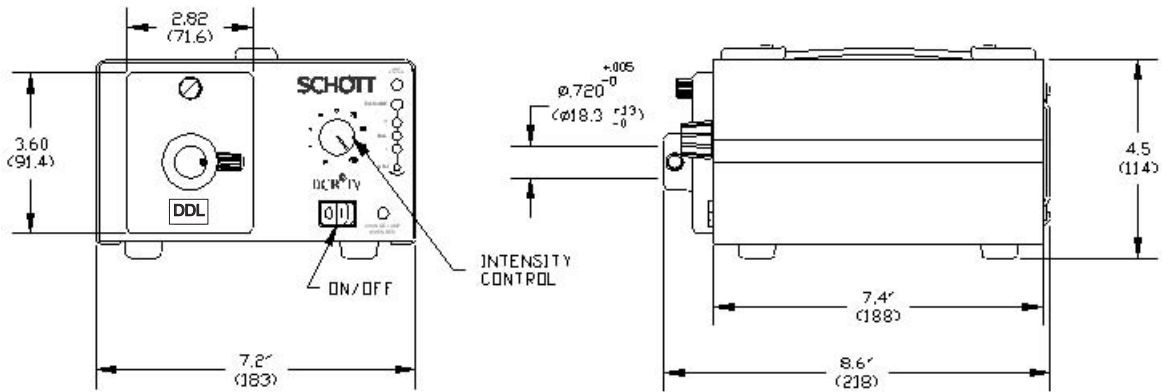

DDL lamp is offered as the standard lamp for this unit.

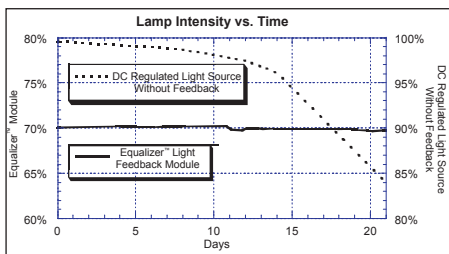

Note: If the intensity control knob is turned to the R (Remote) position, lamp intensity control is switched to the RS232 interface. Front panel intensity control will always override the remote intensity control. Remote control of attached DCR IIIs is dependent on each individual unit's setting, which should be in R (Remote) position for remote control.

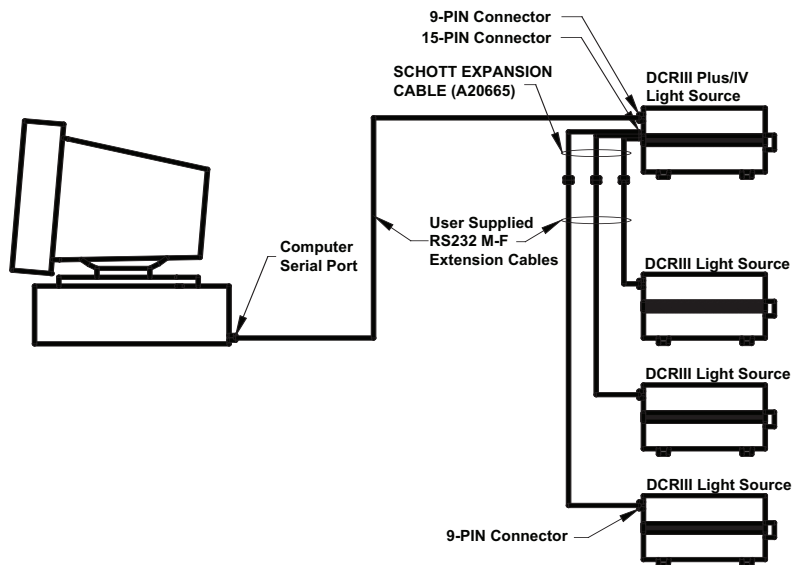

Fiber Optics
SCHOTT North America, Inc.
 62 Columbus Street
 Auburn, NY 13021-3137
 USA
 Phone: +1315/255-2791
 Fax: +1315/255-2695
 E-mail: fiberoptics.auburn@us.schott.com
www.us.schott.com/fiberoptics

